

User Manual

EL-235 Statistical Vibration Logger

Acoustic Research Laboratories

Table of Contents:

COPYRIGHT	3
WARRANTY LIMITATION.....	3
<i>"QUICK START" INSTRUCTIONS</i>	4
INTRODUCTION.....	5
GENERAL SPECIFICATIONS	6
LOGGER HARDWARE	7
LOGGER CASE	7
SENSOR	7
ALARM UNIT.....	7
LOGGER CONTROL PANEL.....	8
EL-235 HOST PROGRAM.....	8
COMMUNICATIONS CABLE	8
MODES OF OPERATION.....	9
RECHARGING THE BATTERY.....	9
STATISTICAL CALCULATION PERIODS	10
THE EL-235 HOST PROGRAM.....	11
INSTALLATION	11
HOST OPERATION.....	11
MENU OPTIONS	12
A SAMPLE LOGGING SESSION	14
PRODUCT SUPPORT	16
INDEX:.....	17

COPYRIGHT

This manual, software and the design data which it describes are copyright with all rights reserved. None of the data may be copied without the express written consent of **ACOUSTIC RESEARCH LABORATORIES PTY LTD (ARL)**.

WARRANTY LIMITATION

Each EL-235 Environmental Vibration Logger is supplied with sensor, communications cable, software, carrying strap and user manual. It carries a 180 day or six months parts and labour warranty against manufacturing defects. If, during the warranty period, a unit fails to perform in accordance with the published specifications, it will be repaired or replaced free of charge. This warranty is void if the equipment has been dismantled, altered, abused in any way or if the operator has not followed user instructions. Authority to return the unit(s) must be obtained from **ARL** prior to shipment. Carriage costs to **ARL** will be paid by the buyer and those for return will be paid by **ARL**.

The above warranty does not include any implied warranty of functionality for a particular purpose. **ARL** assumes no responsibility for damages of any description resulting from the operation or use of its products. Since it is impossible to anticipate all of the conditions under which its products will be used, either by themselves or in conjunction with other products, **ARL** cannot accept responsibility for the results unless it has entered into a contract for services which clearly define such an extension of responsibility and liability.

ARL retains the right to change any specifications without notice as legislative, engineering or manufacturing conditions may warrant.

WARNING

This is a delicate electro-vibration measuring instrument. Although it has been designed for field use, it contains sensitive electronic components which cannot reasonably be expected to withstand high levels of stress and shock. Evidence of negligence in the care and handling of the instrument may void the manufacturer's warranty.

"Quick Start" Instructions

If you are reasonably familiar with vibration measurement techniques, logging instruments and the Windows environment then this page gives all the information you need to get started. We recommend that the entire manual be read prior to using the equipment!

1. Open the logger case, remove the sensor and connect it to the socket on the front of the case.
2. If the logger is not purchased with a battery, connect a 12V battery to the red and black terminals, or to the red and black wires provided inside the logger box. Red is positive (+) and black is negative (-). **Do not connect a battery the wrong way round as it may damage the EL-235!**
3. Connect the serial comms cable provided to the logger (9 pin socket) and to your PC (COM1 or COM2). You may need an adapter if your PC does not have a 25 pin serial port connector.
4. Install the EL-235 software in the same way as you would any other Windows software. (START - RUN - a:\setup)
5. Press the red Wake-Up button on the logger control panel for at least **three** seconds. Run the EL-235 software by double-clicking on the EL-235 icon, and press the **Link** button to start up communication with the logger.
6. Operation of the program is fairly self-explanatory. See the section entitled *EL-235 Host Program* on page 8 of this manual for details.
7. Refer to the section entitled *General Specifications* on page 6 of this manual for details of the instrument specifications.

Introduction

The Enviro-Log-235 has been specifically designed for medium to long term building vibration monitoring, where the preservation of structural integrity and/or the comfort of human occupants is of concern. The instrument measures peak and rms particle velocity, peak and rms acceleration, and human exposure weighted acceleration. Logged results are presented in the form of percentile statistics of vibration, in selected contiguous intervals from one minute to one hour. In addition, the unit may also be configured to log vibration events which exceed a user pre-set threshold.

The logger is housed in a tough weatherproof case with an integral waterproof connector fitted on the front for attachment of the sensor. Space is provided inside the case to fit a 12V/24Ah sealed lead acid battery which provides continuous operation for around two weeks. Other 12V batteries may be used with the corresponding operational life variations. For very long term installations the unit may be configured with a telephone modem and/or solar panel. A telephone connection may be used to control the logger remotely, check battery voltage, download data, reset the unit and re-commence logging.

Normal control and configuration of the logger is accomplished via the EL-235 Host Program which runs under the MS Windows Environment on MS-DOS based personal computers. The host computer is connected to the logger communications port via a 9 pin D connector on the logger. The interface protocol complies with the EIA RS-232C serial communications standard.

A range of optional software utilities, accessories and spare parts are available for the EL-235 from your local representative or from ARL.

General Specifications

The EL-235 has been designed to comply with the basic requirements of the relevant international standards for vibration level measuring instrumentation. General specifications are as follows:

Sensor Type	Tri-Axial Piezo-Ceramic with Integral Pre-Amplifier and Signal Conditioner.
Sensor Output Signal Type	Acceleration
Sensor Frequency Response	1 Hz - 500 Hz
Filter Types	Acceleration: 1.5 - 300Hz Human Response: ISO 2631/DAD 1 (clause 3.4) Velocity: 1.5 - 300Hz
Measurement Ranges	Acceleration: 0 - 0.51m/s/s Human Exposure Curves: 1 – 128 Velocity: 0 - 64mm/s
Primary A/D Range	10 bit (~60dB) (Linear)
Sampling Rate	5 samples / second / channel
Sensor Noise Floor	Acceleration: < 2.0 mm/s rms Human Exposure: < 1.0 mm/s/s Velocity: < 0.1mm/s
Measurement Accuracy	10 %
Detector Types	Peak, true rms.
Statistical Intervals	1,2,3,4,5,6,10,15,20,30 or 60 minutes
Memory Capacity	4096 Statistical Intervals + events
Event Modes	Event Time/Date, Max Levels, Delays to Max Levels, Event 'Energies' (mean levels) and Total Event Duration.
Statistical Mode	Interval Time/Date, Leq, Lmax, L0.1, L1.0, L10 and L90, Temperature, Battery Level
Environmental (operating)	-10°C to +50°C
Alarm/Auxiliary Output Signals	Contact ARL for more details of this optional feature.
Communications Protocol	EIA RS-232-C, 1200 - 19200 Baud, 8 Data Bits, 2 Stop Bits, Hardware Flow Control, Female DB9 Connector
Power Requirements	~72mA @ 12V
Logger Size	350mm x 250mm x 150mm
Logger Weight	~4kg excluding battery
Sensor Size	80mm x 75mm x 60mm
Sensor Weight	~0.8 kg

ARL reserves the right to alter specifications without notice.

Logger Hardware

Logger Case

A rugged weatherproof carry case houses the logger unit. Signal conditioning hardware, the microprocessor controller and the power distribution circuits are contained within a compartment on one side of the chassis. A compartment is provided in the middle for a battery, and space is available beside the battery for a small DAT recorder, ancillary devices, accessories etc. A weatherproof connection for the sensor is provided on front of the unit. Connectors for the host PC, battery charger and auxiliary equipment (optional feature) are provided along the front of the chassis. A Wake-Up button is also provided on the connector panel.

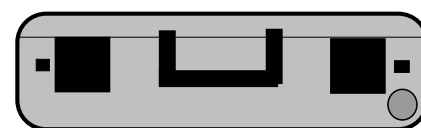

Front View when Closed

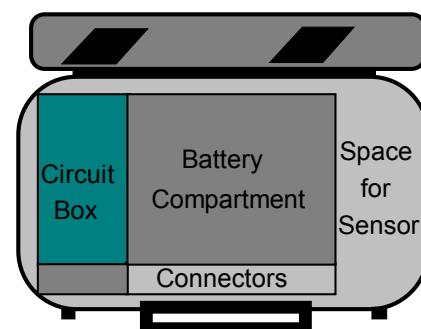

Top View when Open

Figure 1. EL-235 Case.

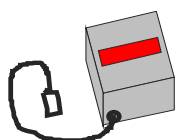

Figure 2. EL-235 Tri-axial Sensor.

Sensor

The sensor comprises three piezoelectric accelerometers tri-axially mounted inside the die-cast aluminum case with associated pre-amplifier circuitry. The sensor attaches to the logger via a cable and an IP-67 rated, water-tight connector. The disconnected sensor may fit

inside the logger case for easy transportation. These units should never be positioned in direct sunlight or exposed to extreme temperature variations. As these sensors are accelerometers they must be treated with the utmost care. The sensor case is not waterproof.

Alarm Unit

Figure 3 below shows the optional alarm unit may be provided with the EL-235. This alarm unit is configured by the host software (see *EL-235 Host Program* on page 8) and connected to the side of the external case. The alarm acts as a switch and is designed to operate an audible or visual (or both) alarm mechanism. The actual alarm mechanism may be powered by the EL-235's battery, an auxiliary battery, or mains power.

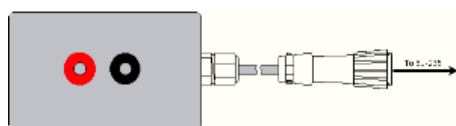

Figure 3. EL-235 Alarm Unit.

Figure 4 below shows the preferred method of connecting the alarm mechanism to the EL-235. The alarm mechanism, in this case a blue strobe light, is powered by an auxiliary battery. This battery could be replaced with a mains powered, 12V DC power supply if mains power is available. The alarm switch is

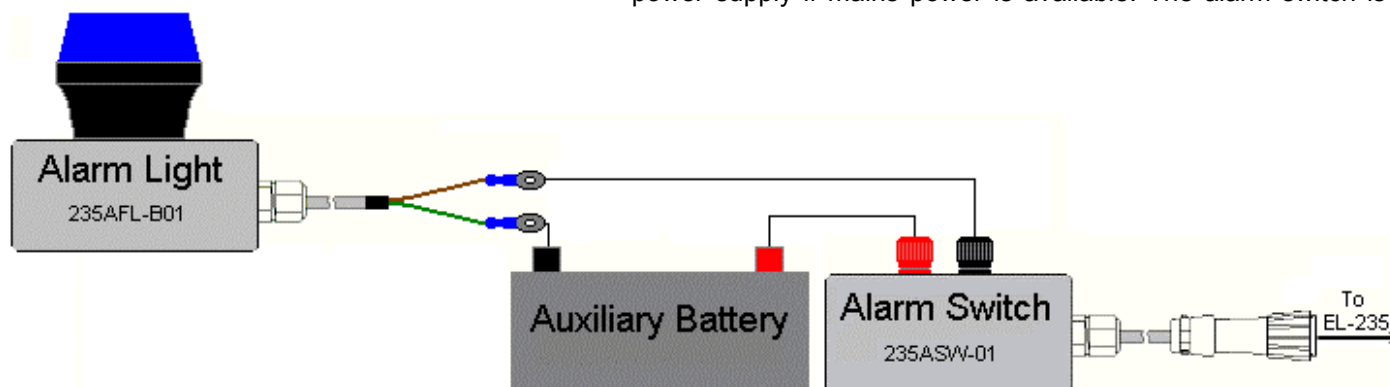

Figure 4: EL-235 Alarm Connection.

controlled by the EL-235 and switches power on and off to the alarm light. This method of connection is the most flexible since any power supply can be used so long as it is appropriate for the alarm mechanism used. It does not drain power from the EL-235 either which leads to extended logging time.

Logger Control Panel

The control panel on the front of the logger provides connection sockets required to operate the instrument. The provided comms cable may be connected between the logger Comms Connector and a spare serial port (Comm 1 or Comm 2) on a PC.

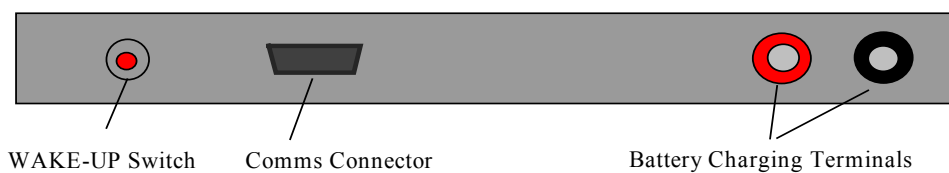
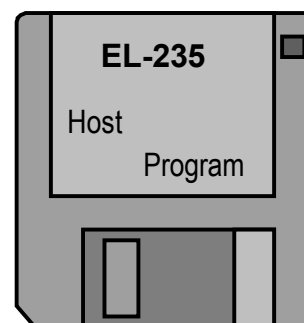

Figure 5. EL-235 Control Panel.

The WAKE-UP button is used to wake up the logger when it has gone into the Sleep Mode.

EL-235 Host Program

This program runs in Windows™ for MS-DOS™ based personal computers, and provides the operator with a means for setting up the logger, downloading and displaying data etc.



Communications Cable

This cable connects the Logger Unit to the PC. It has a 9 pin D connector at the logger end and a 25pin D connector for the computer serial port. A 9-pin to 9-pin connector is available on request when you purchase the EL-235.

Modes of Operation

At any time the logger will be in one of three modes of operation. These three modes are described as follows:-

(1) Logging

In this mode vibration samples are acquired, stored in bins and statistics are calculated and saved at preset intervals. If Capture Vibration Events has also been selected, this data is also recorded and stored for each triggered event. If the alarm system is installed and enabled, an alarm will be triggered if an exceedence occurs. The acquired vibration levels may be displayed in real time by the host program.

This mode will operate until either the battery voltage drops below 10.8V, the memory is filled with logged data or the user elects to stop logging.

(2) Standby

In Standby mode, the logger measures vibration levels, but does not save them, and does not calculate statistics. The measured levels may be displayed by the host program. This mode of operation is analogous to a conventional vibration meter. If no communication is in progress with a host PC for approximately two minutes, the logger shuts down and goes into Sleep mode.

(3) Sleep

When the logger is asleep, the microprocessor and vibration level measuring circuitry is switched off so that battery power is conserved. Any data which is stored on the logger will be retained by battery backed memory. A WAKE-UP button is provided to interrupt the sleep state and place the logger in the standby mode.

Normally, a stored logger which is not logging will be in the sleep mode. When the communications cable is connected and the WAKE-UP button is pressed, the logger 'wakes' and enters the standby mode. The host program may then communicate (Link) with the logger. If no communication with the logger occurs whilst in the standby mode, the logger shuts down in approximately two minutes and goes into the sleep mode.

Logging mode is entered via the **Logging** menu in the host program. Once the logging mode has been started the system cannot enter the sleep mode until the standby mode is selected by the user when the logging session is stopped.

There are however two exceptions to this rule, being when the memory capacity has been reached, or when the battery voltage has dropped to less than approximately 10.8.

Recharging the Battery

In order to maintain maximum operating life, it is recommended that the battery is kept fully charged when the logger is not in use, and is charged as soon as possible after a logging session has been completed. The battery charger should be connected to the terminals provided on the logger control panel.

IMPORTANT NOTE

The battery should not be charged in a sealed environment. If a solar panel has been supplied with the EL-235 then the case lid should be left fully open to prevent any build up of potentially dangerous gas inside the box.

Statistical Calculation Periods

The logger calculates the statistics of the vibration data collected over specified intervals. These intervals vary between 1 min and 1 hour, however the times when each set of statistics are calculated is fixed as follows.

Statistical Interval (mins)	Statistical Calculation Times
1	The start of each minute.
2	The start of each even minute.
3	Every third minute 0,3,6 etc.
4	Every fourth minute 0,4,8 etc
5	Every fifth minute 0,5,10 etc
6	Every sixth minute 0,6,12, etc.
10	Every tenth minute 0,10,20 etc.
15	Every fifteenth minute 0,15,30 etc
20	Every twentieth minute 0,20,40.
30	Every thirtieth minute 0,30.
60	Every hour, on the hour.

If the logger is started at 10:50 with a statistical interval of 30 minutes, then the first statistical calculation will comprise only 10 minutes of data, and will be time stamped in the results as 11:00. The next and subsequent intervals will contain the full 30 minutes of data, and will be time stamped as 11:30,12:00 etc.

The EL-235 Host Program

The EL235 program requires the following computer resources:

- (1) Windows 95 or Windows 98,
- (2) 1 x serial port, and
- (3) VGA graphics display (800 x 600 resolution or better recommended).

Installation

The host control program is supplied on floppy disks. You should install the program by running *setup.exe* on the provided floppy through Windows Program Manager or Windows 9x Start Menu and following the simple install procedure. The program can then be run by selecting it in the Windows 9x Start menu.

Host Operation

Run the host program. The computer will display the standard operating window for the EL-235 logger. It comprises the following elements.

- Menu Bar. Menu items are **File, Measurement, Parameters, Tools** and **Help**,
- Link button to initialise communication between the logger and the Host PC,
- Graphical Vibration Level readout for X-Axis, Y-Axis, Z-Axis and Vector Sum,
- Status readout to show if the logger is operating in Standby or Logging modes. If the logger is logging it will indicate which buffer is being used and the time and date that the logging session started,
- The EL-235 serial number,
- EL-235 time and date,
- Available memory and what buffers are available,
- Logger internal temperature,
- Logger battery voltage,
- Selected Filter Type. ie. Acceleration, Velocity or Human Response,
- Selected Detector Type. ie. Peak or rms,
- Selected Comms Port. ie. COM 1 or COM 2,
- Selected baud rate (19200 fixed).

Communication with the EL-235 logger is initialised using the **Link** button, and terminated with the **UnLink** button. The communications default setup may be modified by choosing **Setup Communications** in the **Parameters** Menu, before linking to the EL-235.

The communication cable should be connected between the EL-235 and the COM1 or COM2 port on the PC. If your PC has a 9 pin serial port you will need a 9 pin female to 25 pin male adapter. This is available from most computer suppliers.

Press the Wake-Up button for at least two seconds and press **Link** to connect to the logger. The program will now read and display the current status of the logger. The status includes the following elements as displayed in the window.

1. Real Time Display of X, Y, Z and Vector Sum values
2. Logger status, serial number, date & time, available memory and buffers, temperature, battery voltage, filter and detector type and PC communications settings.

The logger is now ready to respond to operator commands. Depending upon the current status of the logger, the function menu will display the available options.

Menu Options

File Menu

- Open -** This menu item opens a previously stored data file. The data is organised in a grid fashion similar to a spreadsheet showing all measurement details. This function is only available when the unlinked from the logger.
- Exit -** This option terminates program execution and returns control to the Windows environment.

Measurement Menu

- Logging -** This menu item opens a window with a range of options to begin or complete a logging session by selecting appropriate buttons/options. A measurement title may be chosen (optional) and the statistics interval must be selected. An option is provided to also capture exceeded vibration events and trigger an alarm if connected. If Capture Vibration Events and/or Enable Alarm is selected, further option selection is required.

Trigger Level - This is the vibration level which is to be exceeded for an event to occur.

Trigger On - A selection of X, Y, Z and Vector Sum Axes may be made for which the trigger level is to occur.

Trigger Logic - If the trigger level is to be exceeded for all selected Axes to constitute an event, choose the AND option. Else if only one axes needs to be exceeded to trigger an event, choose the OR option.

Max Length - This is the maximum time an event may occur (1 to 99 sec). If the vibration level still exceeds the trigger level after this time, the event is deemed to be finished.

Separation Time - The vibration level must fall below the trigger level for this duration for the event to be considered complete.

Alarm Length - The length of time for the alarm to be ON after an exceedence is detected.

- Download Data -** This menu selection opens another window which indicates the status of the logger memory. There are four available memory buffers which can represent up to four separate logging sessions. As there is no set memory allocation per buffer, the possibility exists whereby one buffer can utilise the total logger memory, allowing no data storage capacity for remaining buffers.

Data can be cleared or downloaded to the PC by selecting the appropriate buffer. The downloaded data is stored as a comma separated value (CSV) file which may be imported into most commercial spreadsheets.

A "Download All Data" option is available which performs a complete memory retrieval to the PC. This may be useful in the event of logger memory corruption or when a logger has been inadvertently reset. A reset does not clear the memory, but simply sets the relevant pointers to indicate that all buffers are empty when in fact the data is still present. A dump-all ignores buffer pointers and dumps all data.

- Time Capture -** This selection will permit a fast time capture operation to be carried out on any channel to determine structural frequencies. This option is available when the logger is in Standby Mode.

- Track Events -** This menu item opens a window which tracks the status of a vibration event. An event is indicated when the Event In Progress box is checked. At this point an event timer begins after the preset threshold is met. The Maximum Values and time Delay to Maximum(s) are shown for X, Y, Z and Vector Sum Axes. Once the threshold has passed, a Sep (separation) Counter counts down to zero at which

time the event is deemed to have finished.

Parameters Menu

Setup Communications -

This menu item is available only when the logger is Unlinked. It opens a window which allows the PC communications settings to be altered between COM 1 or COM 2 with baud rate settings between 1200 and 19200. (Currently fixed to 19200)

Filtering/Detection -

This menu item opens a window which allows the choice of detector characteristics ie. Peak or RMS, and the choice of filter characteristics ie. acceleration, human response or velocity.

Set Logger Clock -

This option allows the user to adjust the clock time of the logger itself. The time can be manually adjusted or set directly from the time on the PC being used.

Display -

This option allows adjustment of the update rate of the real time display. The update rate can be as high as 10 samples per second. The update rate is simply the rate at which data is requested from the logger for display on the PC. It does not affect operation of the logger.

Options -

This option allows the operator to create a set of default options which the EL-235 will be set to when a reset is performed.

Tools Menu

Calibration -

This menu item opens a window which permits adjustment of the sensor calibration offsets in incremental steps. This is normally only used where a sensor has a known calibration error, and it is to be compensated by the logger. Whilst the calibration window is displayed, the display bars on the main screen are disabled, and the numeric readouts for each channel are averaged and updated twice per second. This permits easier calibration.

Firmware Version -

This option displays the version of firmware currently installed in your EL-235 and the copyright date. The firmware is the software which is installed in the microprocessor card's EPROM. This software is updated periodically such as when new features are added.

Reset -

This allows the user to reset the logger to default status and marks all memory as clear for use.

Link/Unlink -

This menu item performs the same function as the Link/Unlink button in the main window.

Help Menu

Help Contents -

This option opens the help file at the main help contents page (equivalent to pressing the F1 key).

Search for help on -

This opens the help index where you can search for specific help topics and keywords.

About EL235 -

This option gives some basic information about the EL235 Vibration Logger Program.

A Sample Logging Session

This section of the manual describes a typical logging session, with the following requirements:

The unit is to be configured and started in the users' office, and then delivered on-site. After the measurement is complete, it will be delivered back to the office for downloading data. (The alternative to this is to take a laptop on site with the logger and configure and start it in-situ.)

- 15 minute statistics are required.
- RMS Detector Characteristics with Human Response Filtering is required.
- In addition to statistical logging Capture Vibration Events will be enabled with a Maximum Length of 50 seconds and a separation time of 5 seconds. The trigger level is to be 3 mm.s^{-1} on all X, Y, Z and VS axes with AND trigger logic.
- An alarm system will be enabled to warn of vibration level exceedences.

The following steps will complete the vibration logging session as per the above requirements.

- (1) Connect the Communications cable between the logger and a PC Serial Port.
- (2) Start the EL-235 host program.
- (3) Hold down the Wake-Up button on the logger for a few seconds, then press the Link button to link the logger.
- (4) Check that the Battery level is good (above say 12V).
- (5) If the unit is logging, or any previous data has not been downloaded then follow steps 11 - 13 to stop, download and clear the data, before commencing. It is recommended that the EL-235 be reset (select **Tools** → **Reset**) before commencing any logging session.
- (6) The logger memory is now cleared and in Standby mode. If required, select **Parameters** from the menu and then **Filtering/Detection** from the sub-menu. Select RMS detection and Human Response filtering from the current window.
- (7) Select **Logging** from the **Measurement** Menu and configure the logging session as follows.
 - Enter a *Measurement Title*.
 - Select a *Stats Interval* of 15 Minutes.
 - Click on the *Capture Vibration Events* option so that a cross (x) is displayed.
 - Set the *Maximum Length* of 50 seconds
 - Set the *Separation Time* of 5 seconds.
 - Select a *Trigger Level* of 3 mm.s^{-1} .
 - Select all four axis to *Trigger On* (ie. X, Y, Z and VS).
 - Set the *Trigger Logic* to AND.
 - Once all the settings are checked and correct, begin a logging session by pressing the **Start Logging** button. The unit begins logging.
- (8) Unlink the logger to stop communication with the PC. The communications cable may then be disconnected. Disconnect and place the tri-axial sensor inside the logger case before transporting the logger to the desired measurement location. Upon placing the logger in the required position, the sensor should be connected and securely mounted. The unit is then left for the required logging period.
- (9) Upon recovering the logger, the sensor may be disconnected for ease of transportation.
- (10) Re-connect the communications cable, run the host program and link to the logger. The status will be shown as logging, and the measurement details will be displayed on the monitor.
- (11) Select **Logging** from the **Measurement** menu and press the Stop Logging button. The logging session has now been completed and all data is stored in a memory buffer of the logger.
- (12) Select **Download Data** from the **Measurement** menu. The status of all four memory buffers will be shown in a window. The completed logging session details will be shown in the most recently used buffer.
 - To download the last logging session data, select *Download* data from the latest buffer.
 - Enter a filename for the statistical data. eg. SAMP1.CSV (8 Characters Max + CSV extension) and then for the events data. eg. SAMP2.CSV.
 - The statistics data will now be downloaded to SAMP1.CSV and events data to

SAMP2.CSV in the directory selected.

- (13) Press the *Clear Last Buffer* button to delete the data from the logger, and Cancel to return to the main window.
- (14) After a measurement like this the EL-235 battery should be placed on charge, ready for a subsequent logging session. **Do not store the EL-235 with the tri-axial sensor connected.** If your EL-235 is fitted with a "fail-safe" connector, this will drain power from the battery and may cause permanent damage to the battery.

Product Support

Within New South Wales, Australia, this product is supported directly by:-

Acoustic Research Laboratories Pty Ltd

Level 7, Building 2
423 Pennant Hills Road
Pennant Hills, NSW, Australia 2120
(P.O. Box 443, Pennant Hills, NSW, 1715)
Telephone (612) 9484 0800, Facsimile (612) 9484 0884
email: el235@acousticresearch.com.au
<http://www.hutch.com.au/~acoustic>

Index:**A**

Alarm Length	12
Alarm Unit	
Description	7

B

Battery	
Recharging	9

C

Case	5, 7
Communications Cable	8
Communications Protocol	6
Computer Requirements	11
Control Panel	8
Copyright Information	3

E

EL-235	
Description	5
EL-235 Host Software	8, 11
Installation	11
Operation	11

F

File Menu	12
Exit	12
Open	12
Filter Types	6

H

Help Menu	
About EL235	13
Help Contents	13
Search for help on	13

I

Introduction	5
--------------------	---

L

Logging Mode	9
--------------------	---

M

Measurement Menu	12
Download Data	12
Logging	12
Measurement Ranges	6
Memory Capacity	6

Menu Options	12
Modes of Operation	9

N

Noise Floor	
Sensor	6

P

Parameters Menu	13
Display	13
Filtering/Detection	13
Options	13
Set Logger Clock	13
Setup Communications	13
Power Requirements	6

R

Real Time Display	11
-------------------------	----

S

Sample Logging Session	14
Sampling Rate	6
Sensor Frequency Response	6
Sensor Type	6
Separation Time	12
Serial Communication	11
Sleep Mode	9
Specifications	6
Standby Mode	9
Statistical Calculation Periods	10
Statistical Interval	10

T

Time Capture	12
Tools Menu	13
Calibration	13
Firmware Version	13
Reset	13
Track Events	12
Tri-Axial Sensor	7
Trigger Level	12
Trigger Logic	12
Trigger On	12

W

Wake-up button	8, 11
Warranty Limitation	3